



Parts Manual

Mfg. No: 030657-00
5,000 Watt Briggs & Stratton

Model Components	Page
Control Panel (80013210).....	4
Main Unit (80013209).....	6
Wheel Kit (80006254).....	10
Wiring Diagram (80012541wd).....	12
Wiring Schematic (80012541ws).....	14
Torque Specification Chart.....	16

Not For
Reproduction

Control Panel (80013210)

Note: Unless noted otherwise, use the standard torque specifications

Mfg. No: 030657-00

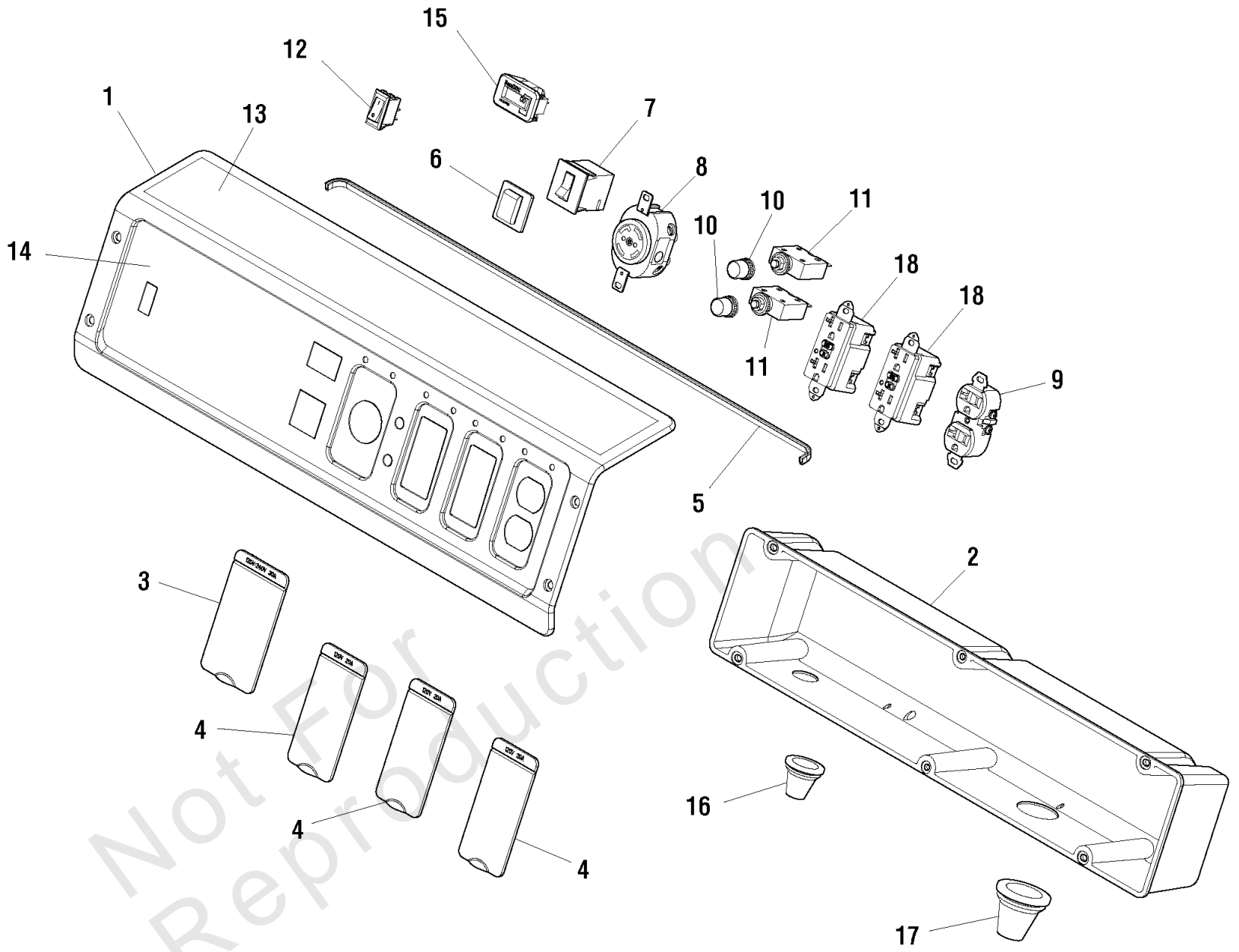

Control Panel (80013210)

REF NO	PART NO	QTY	DESCRIPTION
1	706999		PANEL-CONTROL
2	319458GS		BOX-CONTROL PANEL
3	319477GS		COVER-OUTLET
4	319476GS		COVER-OUTLET
5	319459GS		TRIM-EDGE
6	191481GS		BOOT, Breaker Circuit
7	704197		BREAKER-CIRCUIT
8	43437GS		OUTLET-120/240V, 30A
9	208240GS		OUTLET-120V 20A
10	312636GS		BOOT-CIRCUIT BREAKER
11	209872GS		BREAKER-CIRCUIT 20A
12	319525GS		SWITCH-ON/OFF
13	704194		DECAL
14	706998		DECAL
15	198245GS		HOUR METER
16	319530GS		GROMMET
17	319529GS		GROMMET
18	80409GS		OUTLET-120V GFCI, 20A

Main Unit (80013209)

Note: Unless noted otherwise, use the standard torque specifications

Mfg. No: 030657-00

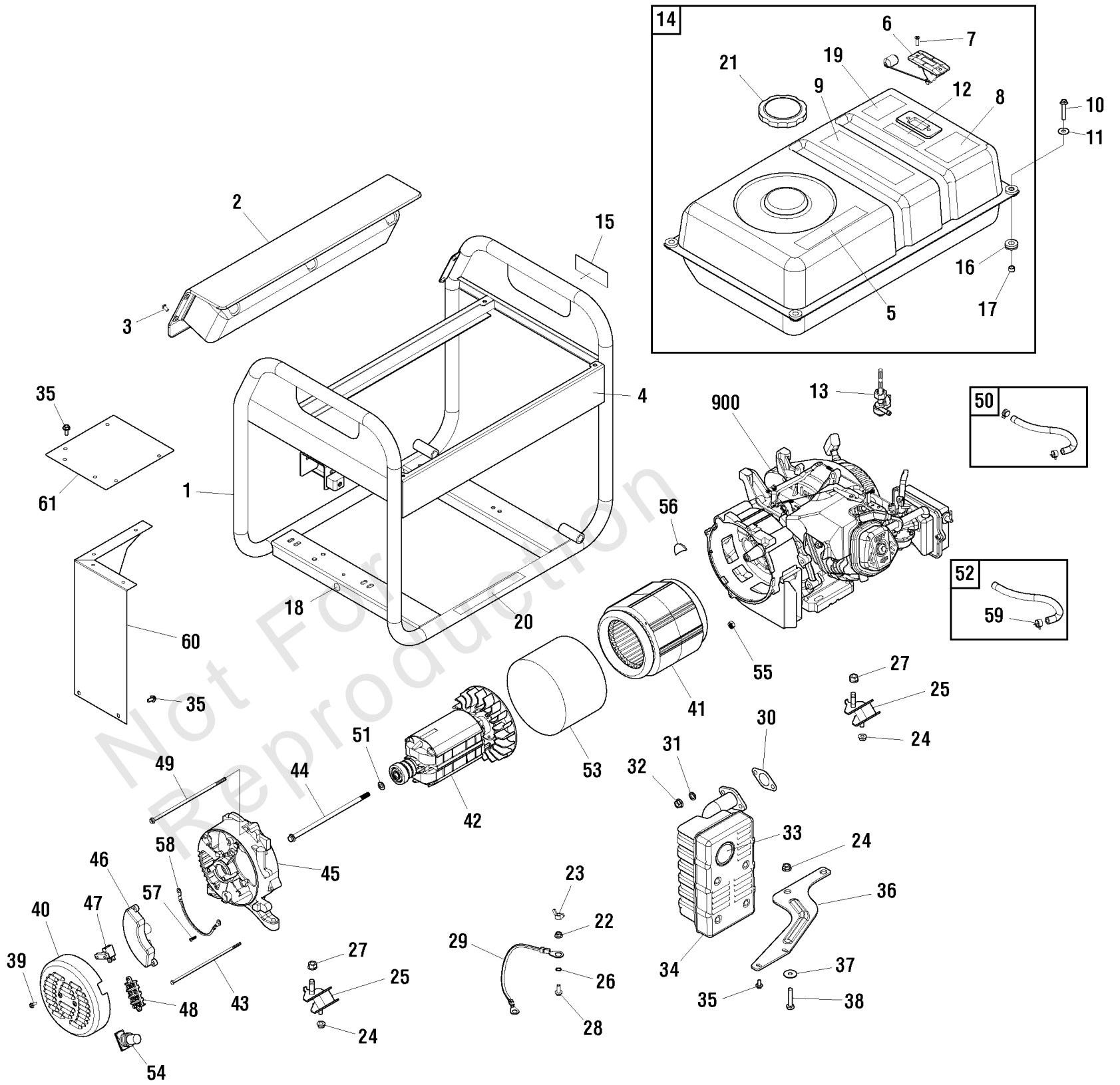

Main Unit (80013209)

REF NO	PART NO	QTY	DESCRIPTION
1	705740		CRADLE
2	707000		PANEL-CONTROL
3	703804		SCREW
4	704191		DECAL
5	704193		DECAL
6	704183		GAUGE-FUEL
7	314440GS		SCREW
8	202997GS		DECAL
9	704186		DECAL
10	703805		SCREW
11	312005GS		WASHER
12	703264		DECAL
13	209417GS		VALVE-FUEL
14	704188		TANK-FUEL
15	704189		DECAL
16	189134GS		GROMMET
17	189137GS		SPACER
18	704331		DECAL
19	704192		DECAL
20	704187		DECAL
21	319587GS		CAP-FUEL
22	-----		* NUT, Flange Lock, M6
23	87680GS		NUT
24	-----		* NUT, Flange Lock, M8
25	319451GS		MOUNT-VIBRATION
26	-----		* WASHER, Shakeproof, Ext, M6
27	-----		* NUT, Flange Lock, M10
28	-----		* SCREW, Flange, M6 x 16
29	706165		WIRE
30	813085GS		GASKET
31	-----		* WASHER, Lock, M8
32	-----		* NUT, Hex, M8-1.25
33	83083GS		SCREEN
34	192569GS		MUFFLER
35	-----		* SCREW, Flange, M6 x 12
36	705501		BRACKET-MUFFLER
37	-----		* WASHER, Flat, M8
38	57821GS		HHCS-M8-1.25 x 40
39	207824GS		SCREW
40	313364GS		END COVER
41	704140		STATOR
42	704202		ROTOR
43	317340GS		BOLT
44	708710		BOLT
45	207838GS		CARRIER-BEARING
46	207840GS		VOLTAGE REGULATOR
47	207827GS		BRUSH ASSY
48	316945GS		TERMINAL BLOCK

Footnotes:

** Contact Engine Manufacturer

* Items without part numbers are common fasteners and are available at your local hardware store.

Main Unit (80013209)

Note: Unless noted otherwise, use the standard torque specifications

Mfg. No: 030657-00

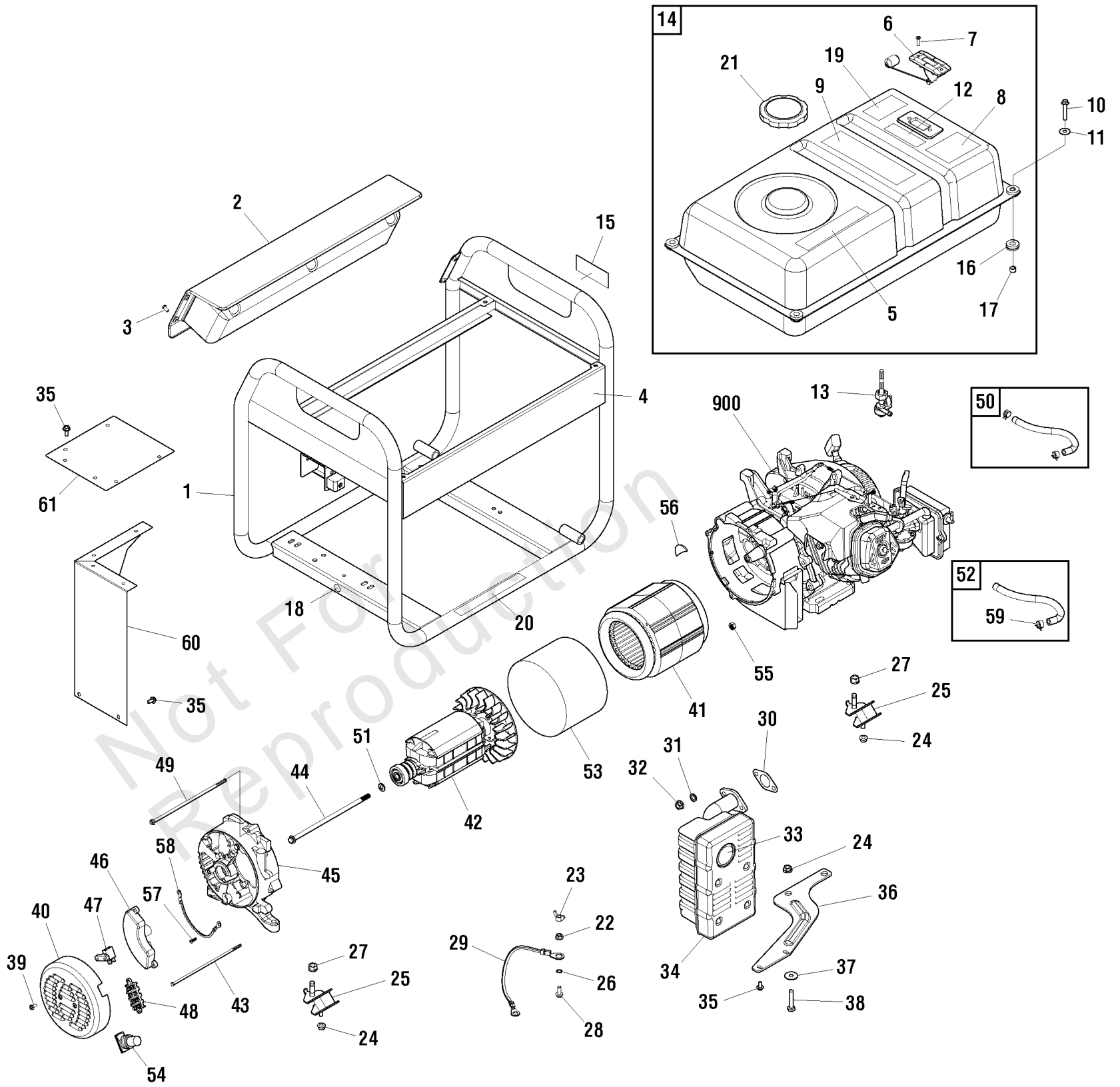

Main Unit (80013209)

REF NO	PART NO	QTY	DESCRIPTION
49	317338GS		BOLT
50	791745		LINE, Fuel
51	207826GS		WASHER
52	315017GS		HOSE-VAPOR (cut to fit)
53	317342GS		BAND-STATOR
54	207879GS		BOOT
55	207878GS		NUT
56	706376		COVER-RUBBER
57	312911GS		SCREW
58	706150		WIRE
59	314955GS		CLAMP
60	705503		HEATSHIELD
61	705489		HEATSHIELD
900	-----		** ENGINE

Not For
Reproduction

Footnotes:

** Contact Engine Manufacturer

* Items without part numbers are common fasteners and are available at your local hardware store.

Wheel Kit (80006254)

Note: Unless noted otherwise, use the standard torque specifications

Mfg. No: 030657-00

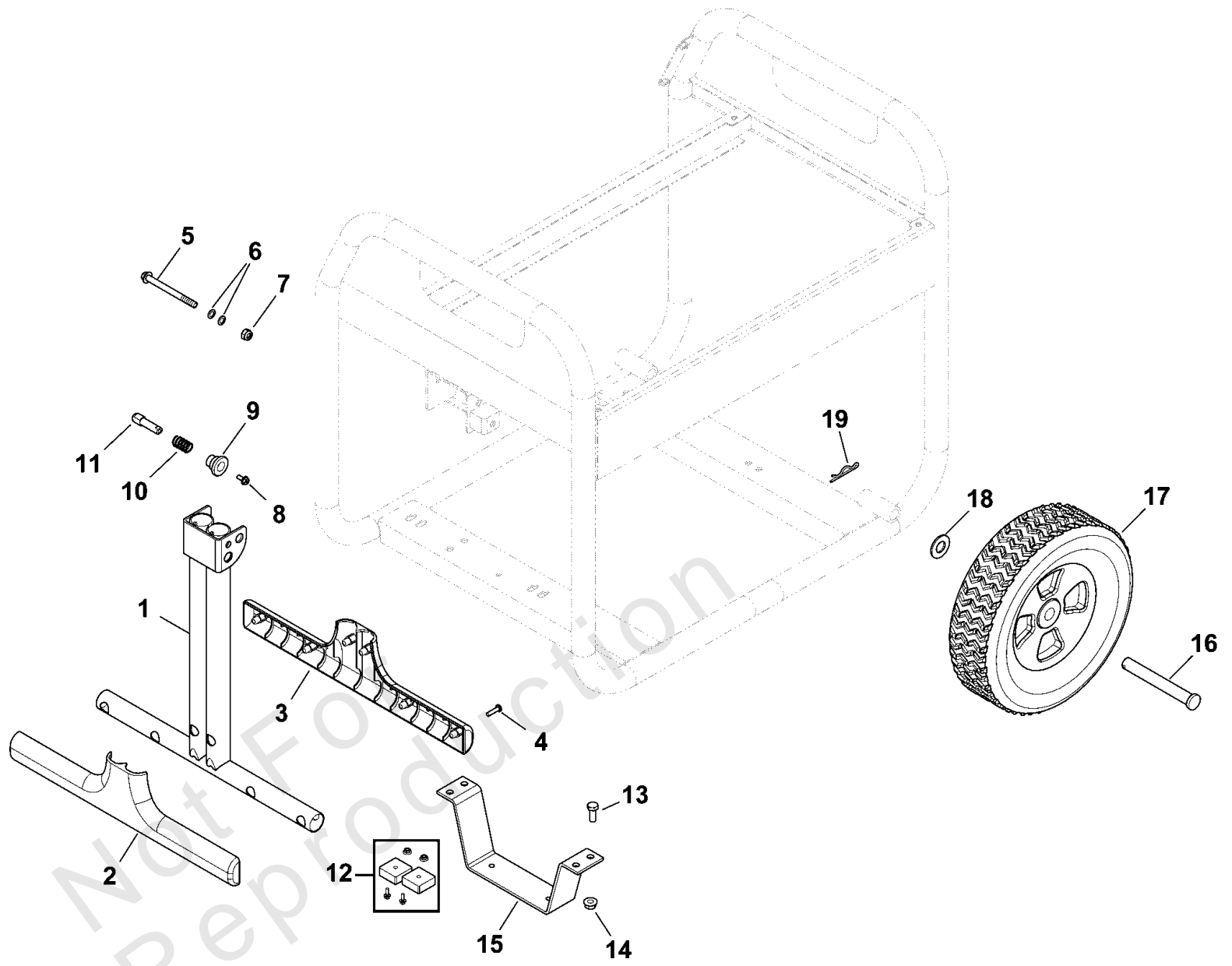

Wheel Kit (80006254)

REF NO	PART NO	QTY	DESCRIPTION
1	319396GS	1	HANDLE
2	319360GS	1	GRIP-HANDLE
3	319361GS	1	GRIP-HANDLE
4	75477GS	6	SCREW
5	318677GS	1	BOLT
6	84002245	2	WASHER
7	49820GS	1	NUT
8	84001685	1	BOLT
9	319453GS	1	KNOB
10	319452GS	1	SPRING
11	319454GS	1	PIN
12	319285GS	1	MOUNT-VIBRATION
13	771804	4	BOLT
14	67989GS	4	NUT
15	704198	1	SUPPORT-LEG
16	703813	2	AXLE
17	704145	2	WHEEL
18	22247GS	2	WASHER
19	316510GS	2	PIN-HAIR

Not For Reproduction

Wiring Diagram (80012541wd)

Note: Unless noted otherwise, use the standard torque specifications

Mfg. No: 030657-00

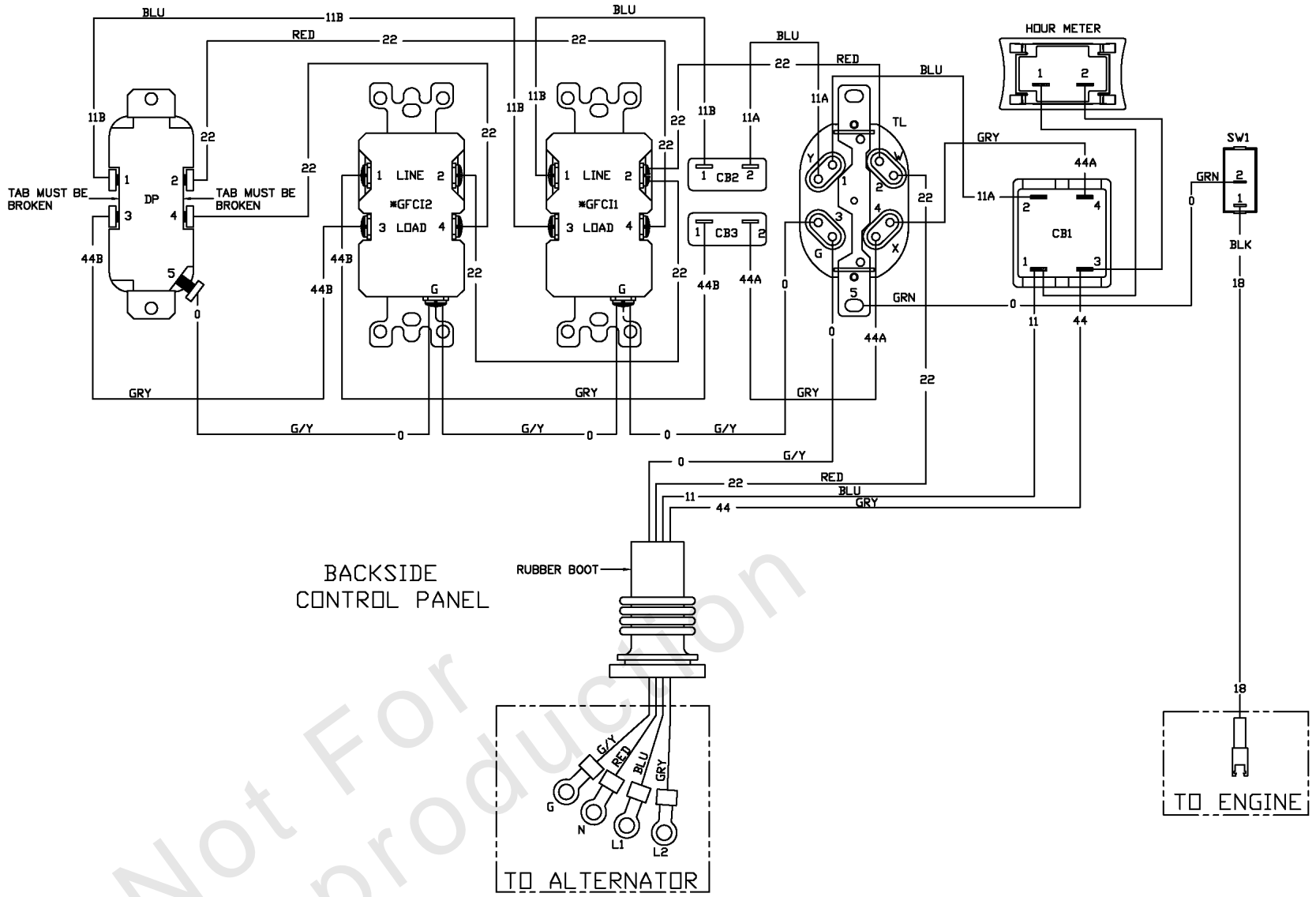

Not For Reproduction

Wiring Diagram (80012541wd)

REF NO	PART NO	QTY	DESCRIPTION
--	-----		Wiring Diagram Only
--	-----		WARNING - Generator Voltage Could Cause Electrical Shock or Burn Resulting in Death Or Serious Injury. To Avoid Electrical Shock Or Burn Hazard, Please Refer Service To Qualified Personnel.

Not For Reproduction

Wiring Schematic (80012541ws)

Note: Unless noted otherwise, use the standard torque specifications

Mfg. No: 030657-00

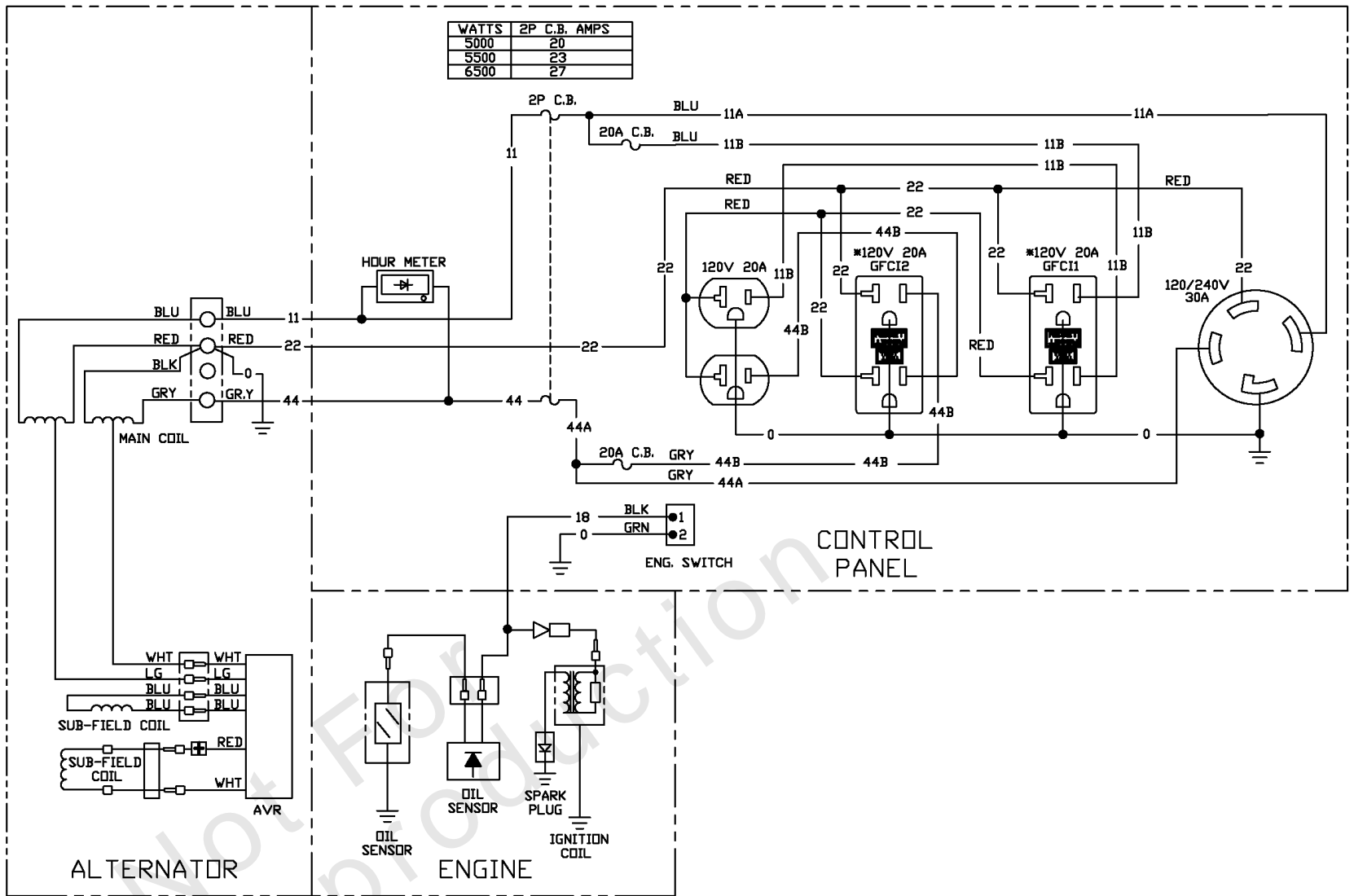

Wiring Schematic (80012541ws)

REF NO	PART NO	QTY	DESCRIPTION
--	----		Wiring Schematic Only
--	----		WARNING - Generator Voltage Could Cause Electrical Shock or Burn Resulting in Death Or Serious Injury. To Avoid Electrical Shock Or Burn Hazard, Please Refer Service To Qualified Personnel.

Not For Reproduction

Hardware Identification & Torque Specifications

Torque Specification Chart								
FOR STANDARD METRIC MACHINE HARDWARE (Tolerance ± 20%)								
Property Class	5.6		8.8		10.9		12.9	
	Class 5.6		Class 8.8		Class 10.9		Class 12.9	
Size Of Hardware	in/lbs	Nm.	in/lbs	Nm.	in/lbs	Nm.	in/lbs	Nm.
	ft/lbs		ft/lbs		ft/lbs		ft/lbs	
M3	5.88	.56	13.44	1.28	19.2	1.80	22.92	2.15
M4	13.44	1.28	30.72	2.90	43.44	4.10	52.56	4.95
M5	26.4	2.50	60.96	5.75	5.97	8.10	7.15	9.7
M6	44.64	4.3	7.3	9.9	10.3	14	12.1	16.5
M7	5.2	7.1	12.1	16.5	16.9	23	19.9	27
M8	7.7	10.5	17.7	24	25	34	29	40
M10	15	21	35	48	50	67	59	81
M12	26	36	61	83	86.2	117	103	140
M14	42	58	101	132	136	185	162	220
M16	64	88	147	200	210	285	250	340
M18	89	121	202	275	287	390	346	470
M20	126	171	290	390	405	550	486	660
M22	169	230	390	530	559	745	656	890
M24	217	295	497	375	708	960	840	1140
M27	320	435	733	995	1032	1400	1239	1680
M30	435	590	995	1350	1401	1900	1681	2280
M33	590	800	1349	1830	1902	2580	2278	3090
M36	759	1030	1740	2360	2441	3310	2935	3980
M39	988	1340	2249	3050	3163	4290	3798	5150

Torque Specification Chart						
FOR STANDARD MACHINE HARDWARE (Tolerance ± 20%)						
Hardware Grade	No Marks		SAE Grade 5		SAE Grade 8	
	SAE Grade 2		SAE Grade 5		SAE Grade 8	
Size Of Hardware	in/lbs	Nm.	in/lbs	Nm.	in/lbs	Nm.
	ft/lbs		ft/lbs		ft/lbs	
8-32	19	2.1	30	3.4	41	4.6
8-36	20	2.3	31	3.5	43	4.9
10-24	27	3.1	43	4.9	60	6.8
10-32	31	3.5	49	5.5	68	7.7
1/4-20	66	7.6	8	10.9	12	16.3
1/4-28	76	8.6	10	13.6	14	19.0
5/16-18	11	15.0	17	23.1	25	34.0
5/16-24	12	16.3	19	25.8	29	34.0
3/8-16	20	27.2	30	40.8	45	61.2
3/8-24	23	31.3	35	47.6	50	68.0
7/16-14	30	40.8	50	68.0	70	95.2
7/16-20	35	47.6	55	74.8	80	108.8
1/2-13	50	68.0	75	102.0	110	149.6
1/2-20	55	74.8	90	122.4	120	163.2
9/16-12	65	88.4	110	149.6	150	204.0
9/16-18	75	102.0	120	163.2	170	231.2
5/8-11	90	122.4	150	204.0	220	299.2
5/8-18	100	136	180	244.8	240	326.4
3/4-10	160	217.6	260	353.6	386	525.0
3/4-16	180	244.8	300	408.0	420	571.2
7/8-9	140	190.4	400	544.0	600	816.0
7/8-14	155	210.8	440	598.4	660	897.6
1-8	220	299.2	580	788.8	900	1,244.0
1-12	240	326.4	640	870.4	1,000	1,360.0

The guides and ruler furnished below are designed to help you select the appropriate hardware.



Nut, M8

Thread Diameter (mm)

Inside Diameter (in) Threads per inch

Nut, 1/2-16



Screw, M8- 1.25 x 25

Thread Diameter (mm) Distance between threads (mm) Body Length (mm)

Body Diameter Threads per inch Body Length (in)

Screw, 1/2- 16 x 2



Standard Hardware Sizing

When a washer or nut is identified as 1/2" (M8), this is the *Nominal size*, meaning the *inside diameter* is 1/2 inch (8mm metric thread diameter); if a second number is present it represents the *threads per inch* (distance between threads).

When bolt or capscrew is identified as 1/2 - 16 x 2" (M8 - 1.25 x 50), this means the *Nominal size*, or body diameter is 1/2 inch (8mm metric thread diameter), the second number, 16, represents the *threads per inch*, (*distance between threads*). The final number is the body length of the bolt or screw, 2 inches (50mm).

NOTES

- These torque values are to be used for all hardware excluding: locknuts, self-tapping screws, thread forming screws, sheet metal screws and socket head setscrews.
- Recommended seating torque values for locknuts:
 - for prevailing torque locknuts - use 65% of grade 5 torques.
 - for flange whizlock nuts and screws - use 135% of grade 5 torques.
- Unless otherwise noted on assembly drawings, all torque values must meet this specification.

Common Hardware Types

Hex Head Capscrew



Washer



Carriage Bolt



Hex Nut

Wrench & Fastener Size Guide

1/4" Bolt or Nut Wrench—7/16"	5/16" Bolt or Nut Wrench—1/2"	3/8" Bolt or Nut Wrench—9/16"	7/16" Bolt or Nut Wrench (Bolt)—5/8" Wrench (Nut)—11/16"	1/2" Bolt or Nut Wrench—3/4"
M6 Bolt or Nut Wrench—10mm	M8 Bolt or Nut Wrench—13mm	M10 Bolt or Nut Wrench—17mm	M12 Bolt or Nut Wrench—19mm	M14 Bolt or Nut Wrench—22mm

